



Values

Group reflection

Purpose

Create shared values for collaborative based on the values of those who make it up (not their organisations).



How to use this tool

- In groups or as a whole, people tell their story using the sheet and others write down on post-its things that are common or really distinct
- Ask people to explain what they have written down and stick into buckets on wall (anyone who has written same to stick over without explaining)
- Print on A3 paper



Our approach to
**supporting
families**

How do we work
with families?

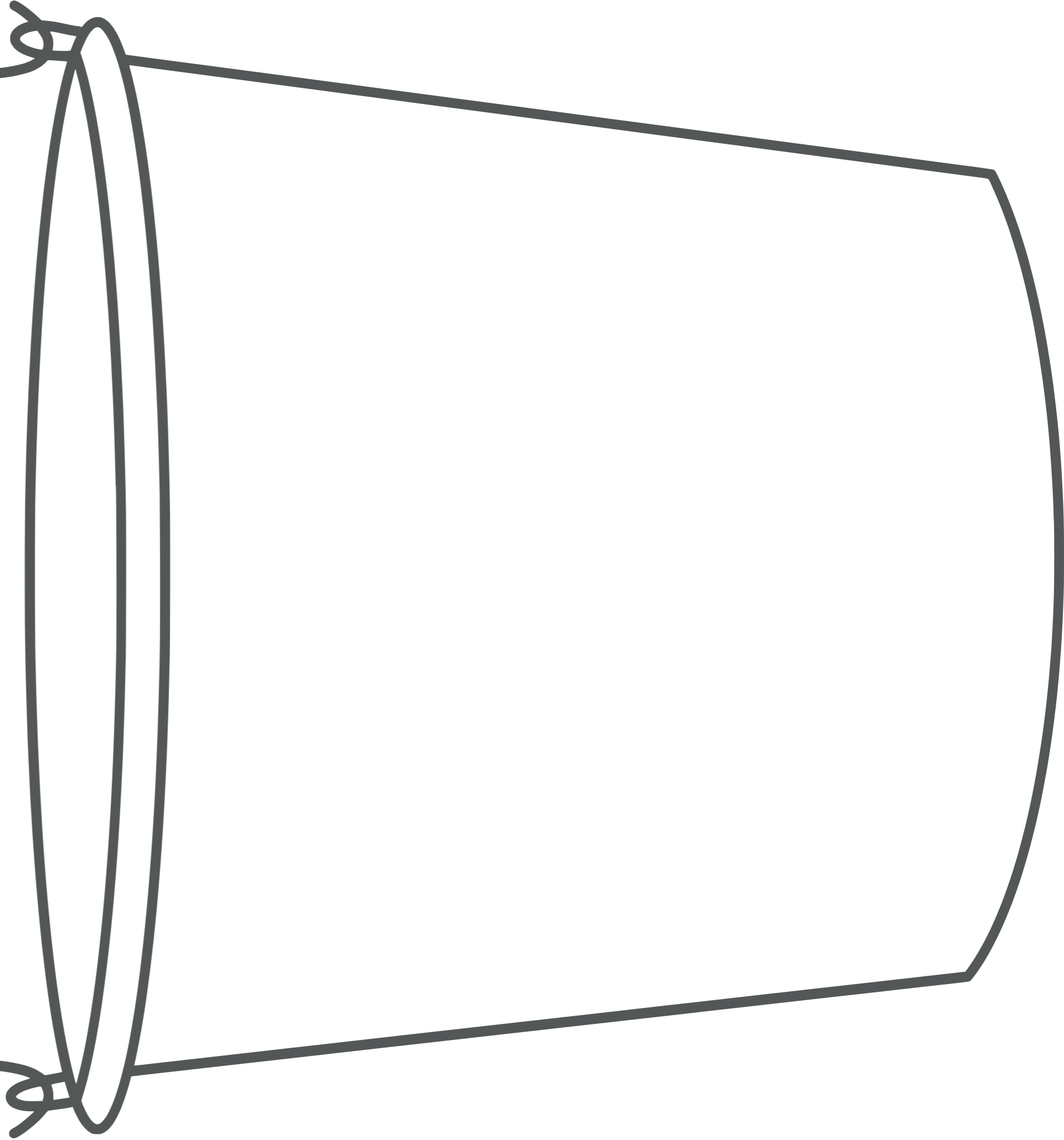



Our approach to
working

cross-sector and
cross-organisations

How do we work
together as partners?

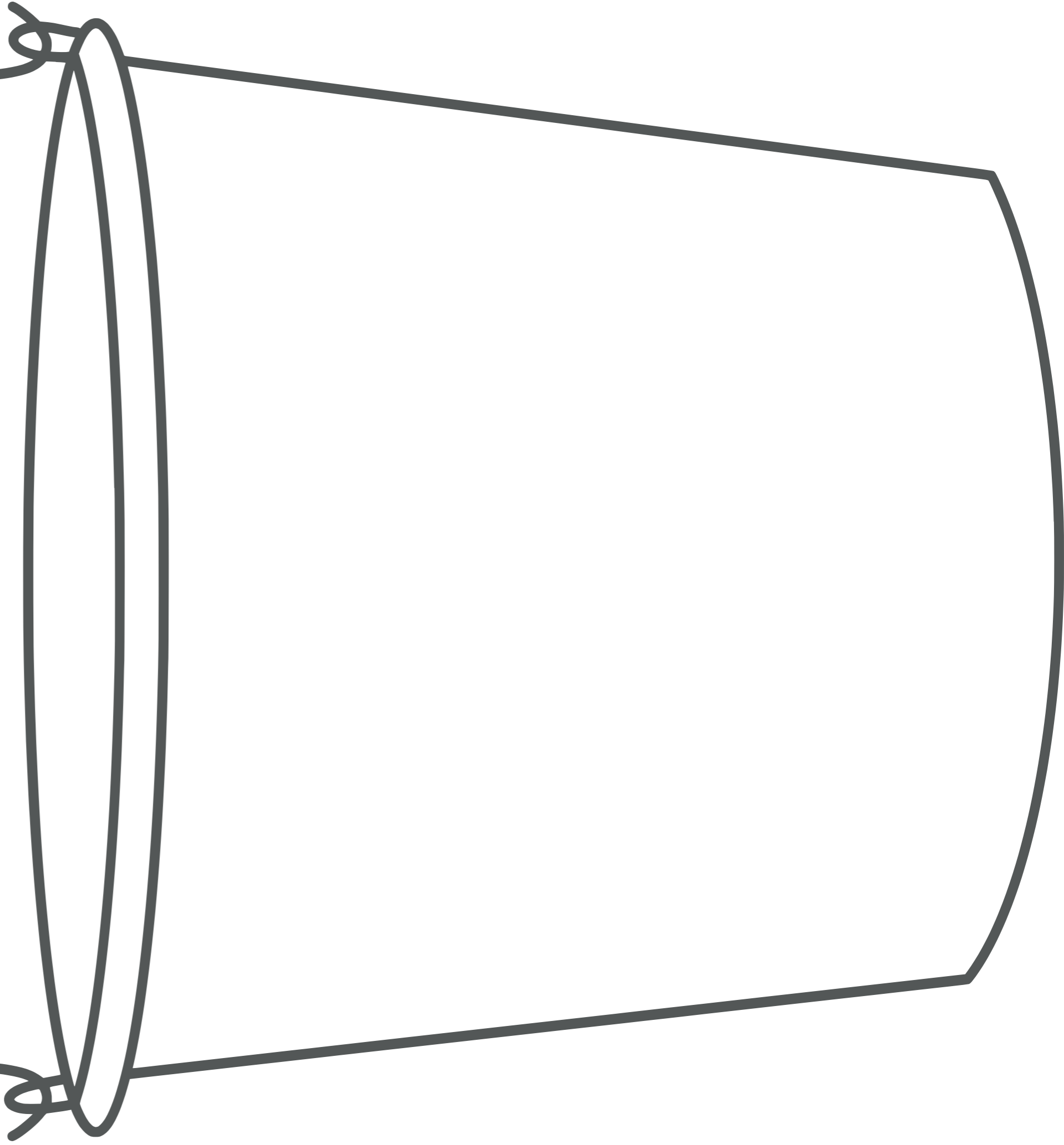



**Our approach to
innovation
and change**

How do we overcome challenges
and react to change?

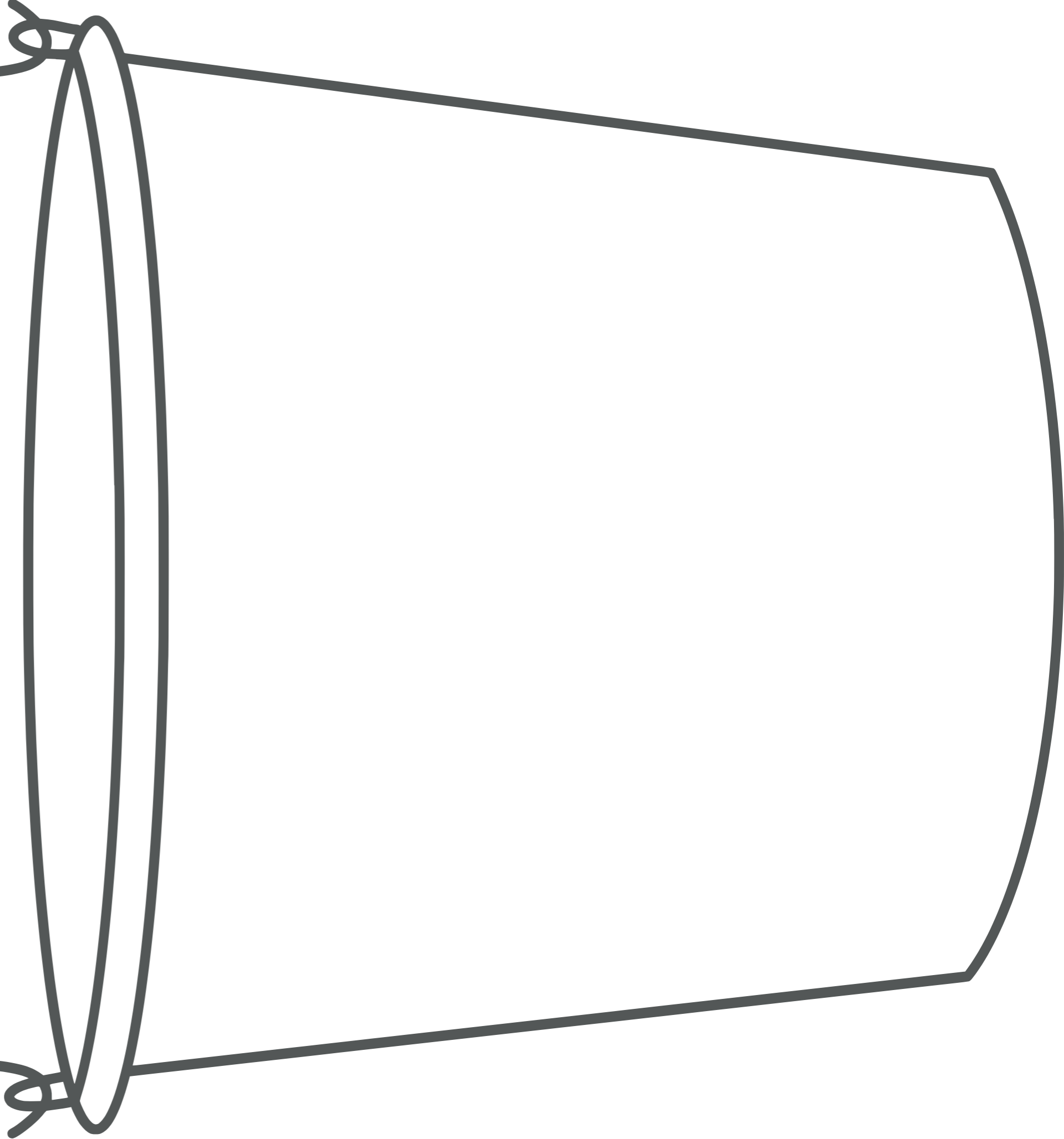



Values

Reflective worksheet

Purpose

Create shared values for collaborative based on the values of those who make it up (not their organisations).



How to use this tool

- Ask everyone to complete their individual value templates
- Print on A4 paper



Reflecting on my personal values and principles

What is it that **drives me** to do what I do?

What am I passionate about **personally**?

What values inform my **leadership**?

What are my personal principles for **working with others**?

What would I like to see **from others**?
(Colleagues, organisations, the Council)

What do **I hope will change** for the better by working collaboratively?